

Troubleshooting Guide v1.5

Manual Addendum: Please refer to these part names when ordering parts. If you ever have service issues with your control head, this addendum will be very helpful in deciding on which o-rings that may need replacing. As with any product, there are parts that will need to be replaced due to normal wear. Below you will find a complete diagram and troubleshooting instructions for Aquadyne filter models .60 through 2.2B with standard 1.5" plumbing ports.

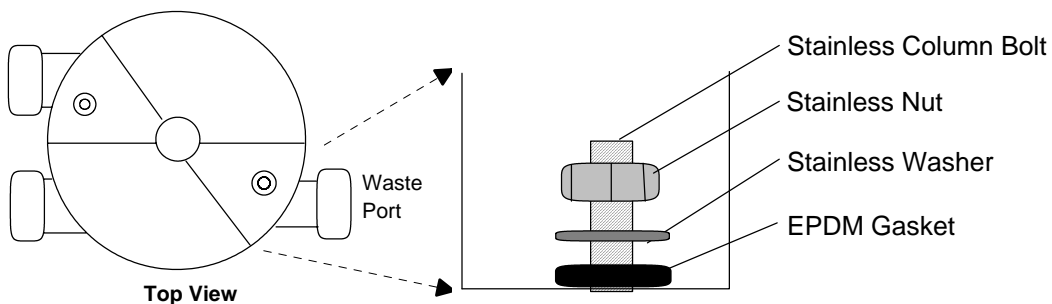
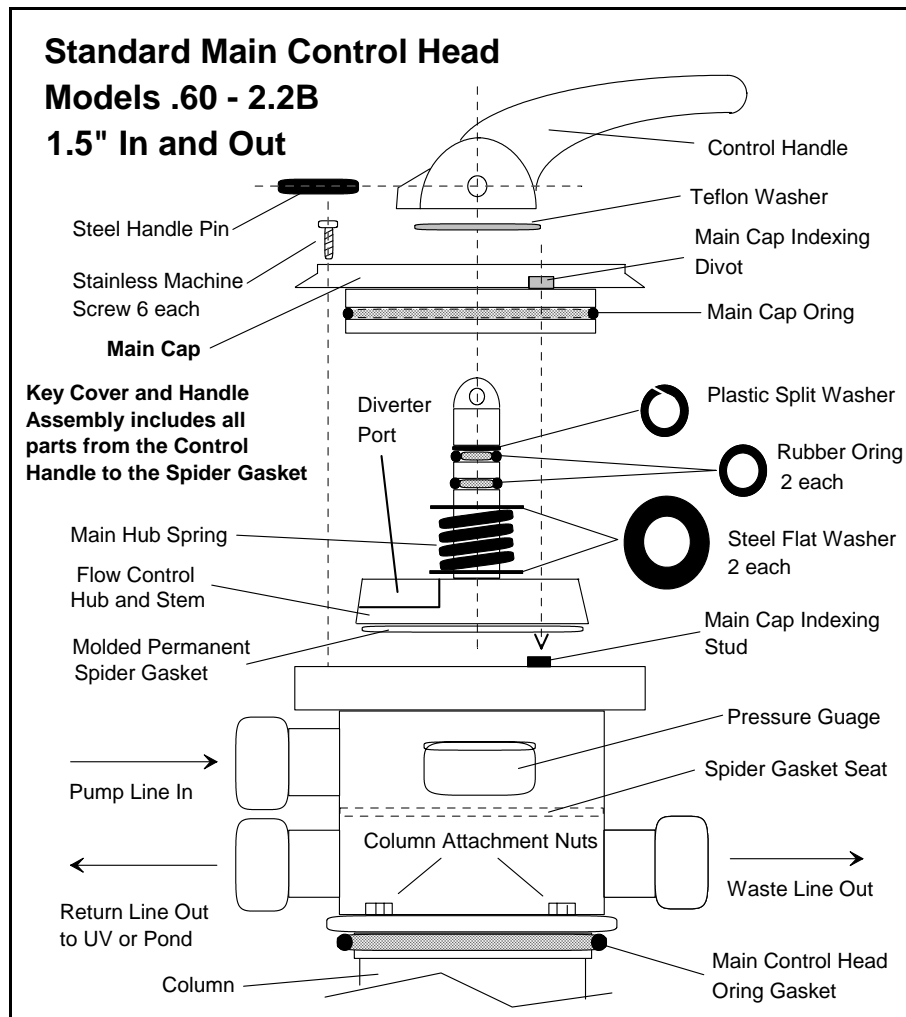

Control Head Trouble Shooting Guide

As with all mechanical things, after some years there are maintenance issues that become apparent and will need to be addressed. Below you will find step by step instruction on how to troubleshoot general maintenance issues.

Water Leaking From Under Control Head Cap

1. Remove 6 machine screws from main cap.
2. Remove Cover O-ring. Clean O-ring and O-ring groove. Lubricate and Reinstall.

* Do not over tighten the screws. Wrist tight only.
If leaking persists, replace o-ring.

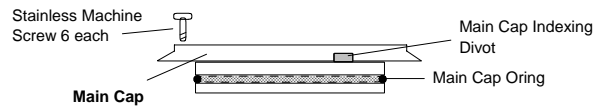

Water Leaking From Waste Line (A)

1. Remove 6 machine screws from main cap.
2. Use 7/16 extension socket and remove the stainless nut from the bottom of the waste line port in the inside of the control head body.
3. Inspect or replace the EPDM o-ring on the bolt shaft then replace the washer and nut and re-tighten.

*Do not over tighten. Tighten wrist tight only to compress the washer.

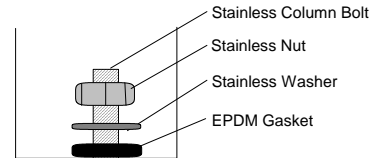

Water Leaking From Waste Line (B)

While dis-assembled, check the Molded Permanent Spider Gasket in the flow control hub. If the gasket is cut or deformed, the Flow Control Hub will need to be replaced. The Spider Gasket is not a separate replacement part. The Spider Gasket is molded into the Flow Control Hub. Do not lubricate this gasket.

Flow Control Hub Removal and Shaft Seal O-ring Replacement

Please refer to the Standard Main Control Head Diagram while following these directions.

1. Using a pin driver or phillips screw driver, drive out the steel handle pin from one side and remove.
2. Remove the control handle and teflon washer.
3. Next remove the 6 stainless machine screws from the cover. Loosen the screws in a circular pattern using 2 revolutions per screw until the screws can be removed. This method allows the release of the spring tension from the main hub spring.
4. Remove the cap and flow control hub from the control head. Twist the flow control hub back and forth and remove it from the center of the main cap.
5. Clean and lubricate or replace diverter hub o-rings.

Re-assembly Instructions

1. Replace steel flat washers and hub spring on the diverter shaft as illustrated. Lubricate shaft o-rings and hole inside the main cap.
2. Insert the stem of the diverter hub into the bottom side of the main cap and press together as far as possible. Rotate the diverter hub until it's port is under the filter position on the cap label.
3. Replace the cap and diverter assembly into the control head body, assuring that the main cap indexing divot and the indexing stud on the body are aligned.
4. Replace the 6 stainless machine screws in the cap and re-tighten them in a circular pattern about 2 revolutions per screw until the cover is secured. This allows for the recompression of the main hub spring. Try to start the screws back into their original thread rather than forcing a new thread.
5. Replace the teflon washer and handle over the stem with the handle pointer towards the filter position.
6. Re-drive the steel handle pin into the handle and through the hub stem. Insert the pin smooth end first.
7. Press the handle down and rotate the pointer to the winterize position. Loosen the 6 screws slightly and re-tighten wrist tight. This will allow the newly lubricated o-ring to seek its center and properly seal.

Some o-rings may need replacing every 2 or 3 years. Others may last much longer.

Only lubricate with potable water o-ring lubricant. ie: silicone grease or other lubricant for o-rings. Do not use Vaseline or petroleum grease. These will damage the o-ring rubber.

Never lubricate a spider gasket or spider gasket seat. This will cause debris to stick to the gasket and seat and can cause the control head to leak.

Filter is loading too quickly between backwash cycles
Water slows down hours after a fresh backwash

Typically, the reason for these occurrences is that the media depth is too low. This can occur as a result of excessive bead loss through the sludge valve, usually over a period of years. It is common to lose a few beads when opening the sludge drain. This loss usually amounts to no more than 1 to 2 pounds of media per year. Over time this adds up and the bead depth is reduced. The lower the bead media depth the less media there is to trap waste products therefore the media loads faster. Bead loss can also occur due to improper backwashing. Opening the sludge valve only when the filter is in filter position minimizes bead loss. In the filter position the media is floating and compacted towards the top of the filter and away from the sludge valve. The following are instructions on how to gain access to the media and measure the bead media depth.

Control Head and Column Removal

1. Turn off pump and attached equipment.
2. Detach all PVC lines from the control head. This is typically done by unscrewing union connectors.
3. Using a #2 Phillips head screwdriver, remove the 2 screws on either side of the neck clamp that attaches the black control head to the beige tank and remove the neck clamp from the tank.
4. Lift straight up on the control head and the entire head and column can be easily removed.

Note: When removing column from tank, always inspect it thoroughly. Remove any beads that might have become trapped in the upper slots. Typically, some media will become trapped in the upper slots over time, which if significant can cause the flow rate through the filter to decrease. The slots in both the upper and lower sections are engineered to maintain a proper flow rate even when 75% blocked.

Aquadyne Head and Column Assembly

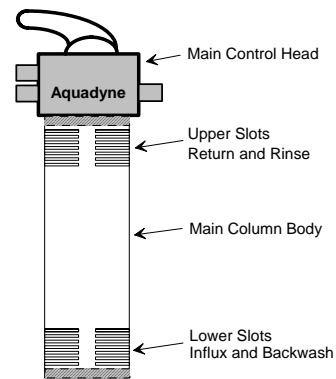

The Aquadyne Flow Control System is a Patented Product
That is Protected under United States Patent Law.

Measuring the Bead Media Depth

Remove the control head and column as directed above.

Fill the tank with water until the beads float 2 to 3 inches below the tank opening. Insert a measuring device and reach into the beads and guide the end of the measuring device level with the bottom of the floating bead media. Take the bead depth reading from the surface of the media at the tank opening. It is not recommended to exceed the measurement capacity by more than 10% when adding media to the tank.

Bead Capacity by Depth Measure

Models .60 and .60-B --- 8.5 inches	Models 1.1 and 1.1B --- 10.5 inches
Models 2.2 and 2.2-B --- 13.5 inches	Model 4.4 --- 15.5 inches

Water Does Not Flow Through the Sludge Drain

If water will not flow through the sludge drain when opened, there is heavy sedimentation that has stopped up the drain. It is necessary to open the sludge drain momentarily to evacuate sedimented solids from the lower sedimentation area of the filter every time that you backwash your filter system. If the sludge drain of your Aquadyne system is not opened for extended periods of time, sedimented waste products in the bottom of the filter can solidify and block the passage of water through the drain. You should open the sludge drain at least 2 times per month, whether or not you backwash your filter that often. Always open the sludge drain with the filter running in the filter position to drain solid waste from the filter system. There are three ways to attempt to clear the drain.

- #1. Open the stopped up drain and insert a small diameter flexible shaft with an upturned end (hedge branch) into the drain pipe and force it past the elbow into the tank. If the obstruction is light, this should clear the drain.
- #2. Acquire a hose fitting from the hardware store that will allow you to connect your garden hose to the 1" sludge drain fitting. With the pump off, and the control head set to rinse, apply pressure to the garden hose from the house spigot. The hose pressure should break any heavier blockage.
- #3. If the drain has not been opened in quite a while and you suspect a severe blockage then it is best to remove the control head and column from the tank as described above and reach down to the bottom of the tank and feel for the obstruction and physically remove it. If you cannot reach the bottom of the tank, then use a broom handle to scrub the debris loose from the bottom tank wall. Then use a small diameter rod or even a screw driver and wiggle it into the lower elbow from inside the tank with the sludge drain open. This will most definitely free the obstruction.